



# Audiopipe®

Hwy 836, U.S.A.

**EXT™**  
*Edge extension Technology*

**User's Manual**



**TXX-BF10**

**TXX-BF12**

**TXX-BF15**

***Introduction:***

Congratulations on your purchase of an Audiopipe subwoofer incorporating EXT technology. Your Audiopipe subwoofer has been engineered to produce the highest quality sub-bass performance in your vehicle. Audiopipe dealers have the knowledge, skills to build high-quality enclosure that will maximize the performance of your subwoofer. We highly recommend that you have your enclosure built by an Audiopipe authorized dealer. For more dealer information in your area do visit .

All Audiopipe products are designed, manufactured and tested to perform in the harsh environments. From our entry level products to our high end series, Audiopipe is your best choice for competition level performance.

We welcome you to team Audiopipe.....

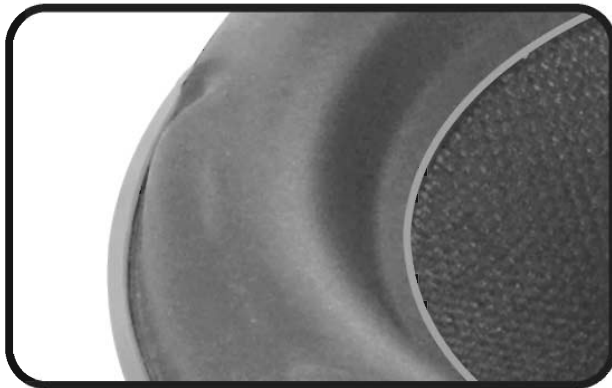

***Special large Foam edge surround***

***Table of Contents:***

Specifications	_____	1
Dimensions	_____	2
Sealed Applications	_____	3
Vented Applications	_____	4
Wiring Diagrams	_____	5
Wiring Diagrams	_____	6



### ***Specifications:***

	<b>TXX-BF10</b>	<b>TXX-BF12</b>	<b>TXX-BF15</b>
Free air response (FS)	34Hz	28Hz	25Hz
Electrical "Q" (Qes)	0.573	0.54	0.52
Mechanical "Q" (Qms)	2.95	3.0	2.1
Total Speaker "Q" (Qts)	0.48	0.47	0.45
One way, Linear Excursion (Xmax)	13mm	13mm	15mm
Efficiency (1W/1m)	89dB	93dB	97dB
Effective Piston Area (sd)	0.0346M <sup>2</sup>	0.057M <sup>2</sup>	0.0979M <sup>2</sup>
DC resistance (Re)	2x3.6Ω	2x3.6Ω	2x3.6Ω
Nominal Impedance	2x4Ω	2x4Ω	2x4Ω
Power Handling	700/1400W	900/1800W	1200/2400W
Mounting Depth	173mm 6 13/16"	193mm 7 5/8"	219mm 8 5/8"
Mounting Hole Diameter	Ø242mm 9 1/2"	Ø294mm 11 9/16"	Ø370mm 14 9/16"

**Dimensions:**

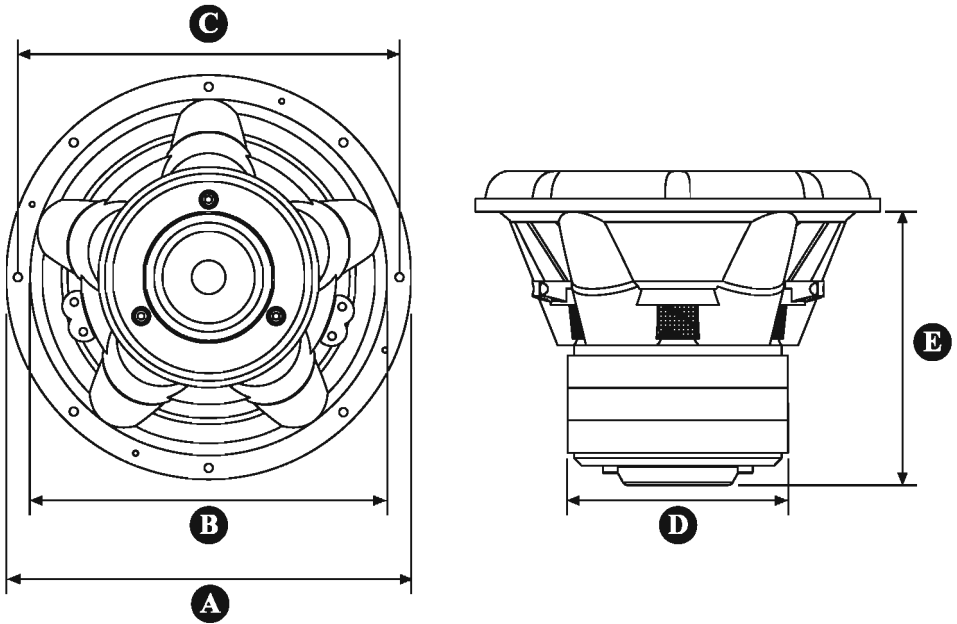

	<b>A</b>	<b>B</b>	<b>C</b>	<b>D</b>	<b>E</b>
<b>TXX-BF10</b>	Ø258mm 10 3/16"	Ø225mm 8 7/8"	Ø242mm 9 1/2"	Ø156mm 6 1/8"	173mm 6 13/16"
<b>TXX-BF12</b>	Ø312mm 12 5/16"	Ø275mm 10 7/8"	Ø294mm 11 9/16"	Ø180mm 7 1/16"	193mm 7 5/8"
<b>TXX-BF15</b>	Ø388mm 15 1/4"	Ø351mm 13 7/8"	Ø370mm 14 9/16"	Ø190mm 7 1/2"	219mm 8 5/8"

## Sealed enclosure applications

Primary advantages: Small, good low frequency extension and control, simple to build.

This type of enclosures is a classic design and the easiest to build among most installers. These enclosure recommendations have been calculated with the airspace inside and include the displacement of the woofer. All sealed enclosure designs should be filled to 50% with loose poly-fil stuffing. The use of poly-fil will slightly decrease efficiency but will deepen and extend the low frequency output.

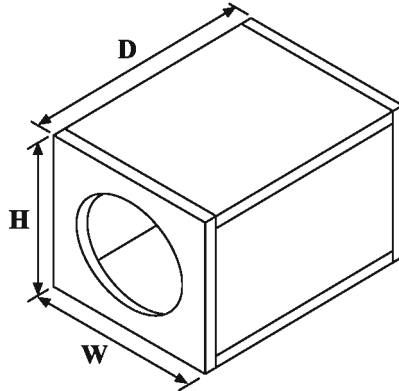

Subwoofer	Recommended Sealed Enclosure	
	Volume (net int.)	External Dimensions (Width x Height x Depth)
<b>TXX-BF10</b>	1.0 FT <sup>3</sup>	12" x 12" x 13"
<b>TXX-BF12</b>	1.75 FT <sup>3</sup>	14" x 14" x 16"
<b>TXX-BF15</b>	2.25 FT <sup>3</sup>	16" x 16" x 18"

### Box building notes

Use 3/4" or thicker MDF (medium density fiberboard) and seal the joints with silicone. All the cubic ft measurements in this manual include the displacement of the woofer and port. All ports have been calculated using rectangular ports it would be impractical to use round ports for these designs. Do not install ports opening against a solid surface, such as an internal brace, back panel or seat of your vehicle. The port opening must remain unobstructed.

## Vented enclosure applications

Primary advantage: Efficient, low distortion around port tuning.

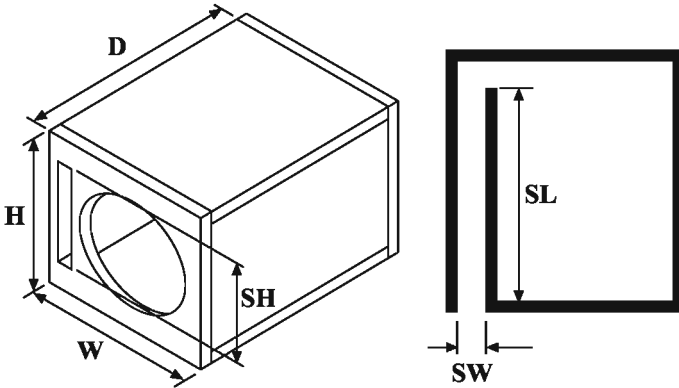

These enclosures are the installer's choice for high performance SPL levels and require a deeper understanding in order to achieve maximum efficiency. These enclosure recommendations have been calculated with the airspace inside and include the displacement of the woofer.

Subwoofer	Recommended Ported Enclosure		
	Volume (net int.)	Enclosure External Dimensions (Width x Height x Depth)	Slot Port Internal Dimensions (Slot Width x Slot Height x Slot Length)
TXX-BF10	1.25 FT <sup>3</sup>	14" x 14" x 17.5"	1.25" x 9.5" x 16.5"
TXX-BF12	2.00 FT <sup>3</sup>	16" x 16" x 16"	1.25" x 11.5" x 16"
TXX-BF15	2.50 FT <sup>3</sup>	18" x 18" x 16"	1.25" x 14.5" x 15"

### Wiring options

The TXX-BF series of subwoofers are available with dual 4 Ohms voice coils. Both coils must be connected to a source of amplification. A dual 4 Ohms woofer can be configured in parallel to provide a 1 Ohm load. A dual 4 Ohms woofer can be also configured in series to provide a 8 Ohms load. The terminal with the red markings is the positive while the black terminals represent the negative.

Series Wiring for Dual Voice Coil 2Ω Sub

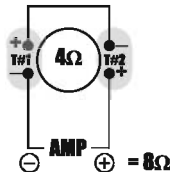

Parallel Wiring for One Dual Voice Coil 4Ω Subs

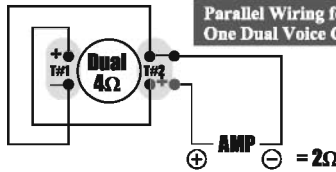

# Other useful wiring options

T#1 = Terminal #1

T#2 = Terminal #2

Parallel Wiring for Two Single Voice Coil 4Ω Subs

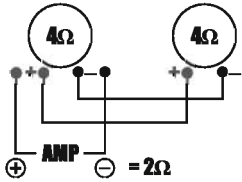

Series/Parallel Wiring for Two Dual Voice Coil 2Ω Subs

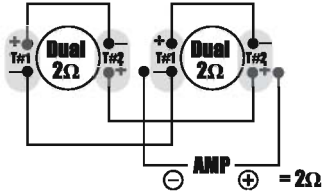

Parallel Wiring for Four Single Voice Coil 4Ω Subs

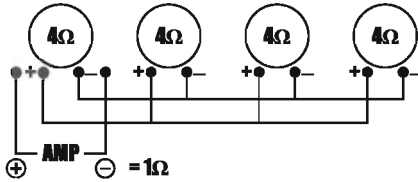

Series/Parallel Wiring for Four Single Voice Coil 4Ω Subs

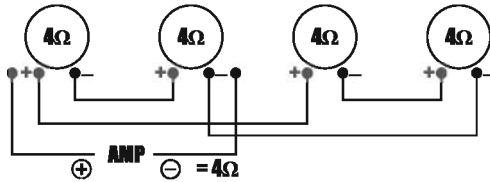

Series/Parallel Wiring for Four Dual Voice Coil 4Ω Subs

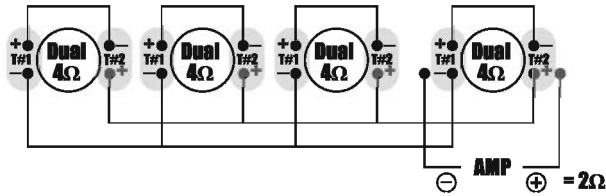

Parallel Wiring for Dual Voice Coil 2Ω Sub

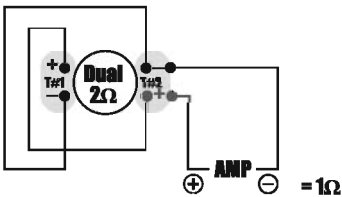

Series Wiring for Dual Voice Coil 2Ω Sub

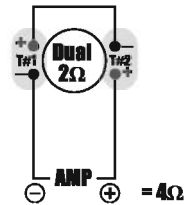

# Other useful wiring options

T#1 = Terminal #1

T#2 = Terminal #2

**Series/Parallel Wiring for Three Dual Voice Coil 2Ω Subs**

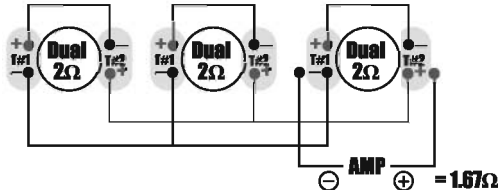

**Parallel Wiring for One Dual Voice Coil 4Ω Subs**

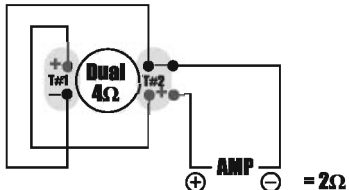

**Parallel Wiring for Two Dual Voice Coil 4Ω Subs**

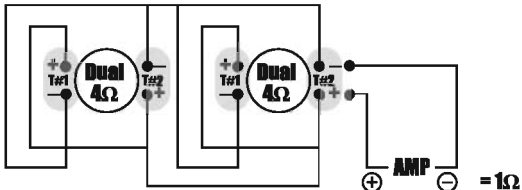

**Series/Parallel Wiring for Four Dual Voice Coil 2Ω Subs**

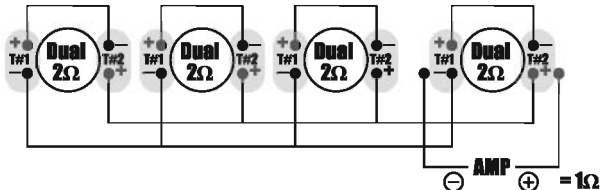

**Series/Parallel Wiring for Three Dual Voice Coil 4Ω Subs**

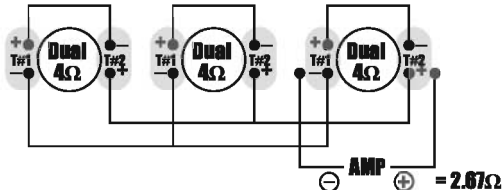

**Series/Parallel Wiring for Two Dual Voice Coil 4Ω Subs**

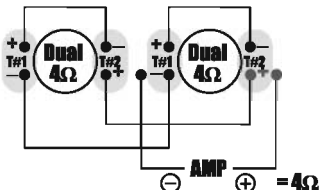



**Audiopipe®**

Hwy 836, U.S.A.



**Manual del Usuario**



**TXX-BF10**

**TXX-BF12**

**TXX-BF15**

## ***Introducción:***

Felicitaciones en su compra del subwoofer Audiopipe que incorpora tecnología EXT. Su subwoofer Audiopipe ha sido fabricado para producir el mayor rendimiento y calidad del bajo del subwoofer en su vehículo. Los concesionarios Audiopipe tienen conocimiento y experiencia para construir cajas de alta calidad que incrementarán al máximo el rendimiento de su subwoofer. Le recomendamos que usted haga construir su caja por un concesionario Audiopipe autorizado. Para más información acerca de concesionarios en su área visite: [www.audiopipe.com](http://www.audiopipe.com).

Todos los productos Audiopipe están diseñados, fabricados y comprobados para máximo rendimiento aun en las condiciones externas más duras. Desde nuestros productos más económicos hasta nuestras series de alta gama, Audiopipe es su mejor selección para competiciones de rendimientos de alto nivel.

Le damos la bienvenida al team Audiopipe....

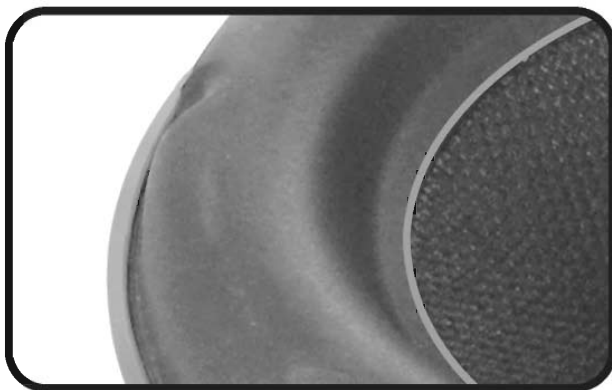

***Borde circundante especial de espuma***

## ***Tabla de Contenidos:***

Especificaciones	1
Dimensiones	2
Aplicaciones de la Caja Sellada	3
Aplicaciones de Cajas con Orificios	4
Diagramas de Cableado	5
Diagramas de Cableado	6



### ***Especificaciones:***

	<b>TXX-BF10</b>	<b>TXX-BF12</b>	<b>TXX-BF15</b>
Free air response (FS)	34Hz	28Hz	22Hz
Electrical "Q" (Qes)	0.573	0.54	0.52
Mechanical "Q" (Qms)	2.95	3.0	2.1
Total Speaker "Q" (Qts)	0.48	0.47	0.45
One way, Linear Excursion (Xmax)	13mm	13mm	15mm
Efficiency (1W/1m)	89dB	93dB	97dB
Effective Piston Area (sd)	0.0346M <sup>2</sup>	0.057M <sup>2</sup>	0.0979M <sup>2</sup>
DC resistance (Re)	2x3.6Ω	2x3.6Ω	2x3.6Ω
Nominal Impedance	2x4Ω	2x4Ω	2x4Ω
Power Handling	700/1400W	900/1800W	1200/2400W
Mounting Depth	173mm 6 13/16"	193mm 7 5/8"	219mm 8 5/8"
Mounting Hole Diameter	Ø242mm 9 1/2"	Ø294mm 11 9/16"	Ø370mm 14 9/16"

**Dimensiones:**

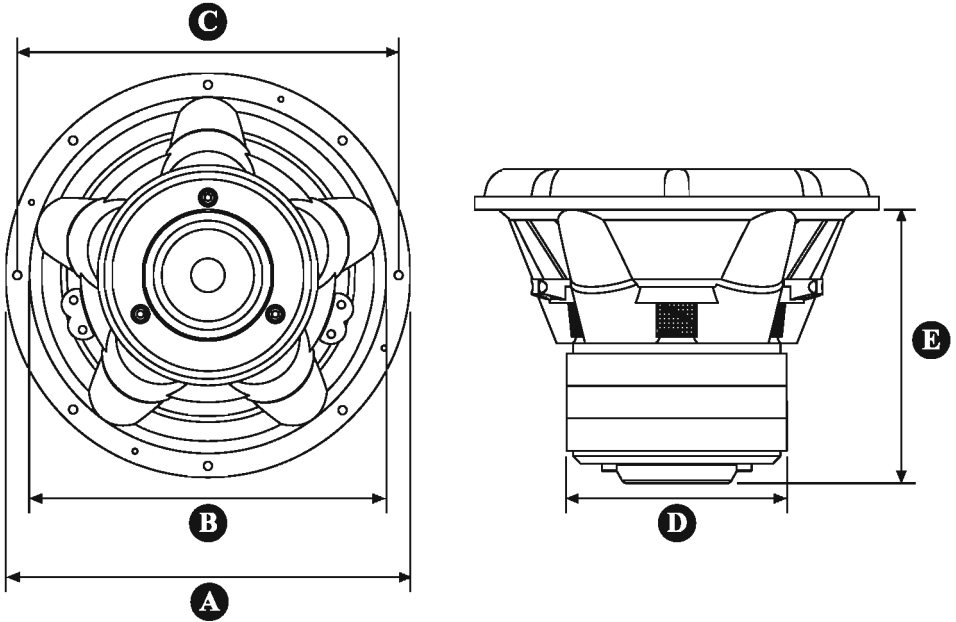

	<b>A</b>	<b>B</b>	<b>C</b>	<b>D</b>	<b>E</b>
<b>TXX-BF10</b>	Ø258mm 10 3/16"	Ø225mm 8 7/8"	Ø242mm 9 1/2"	Ø156mm 6 1/8"	173mm 6 13/16"
<b>TXX-BF12</b>	Ø312mm 12 5/16"	Ø275mm 10 7/8"	Ø294mm 11 9/16"	Ø180mm 7 1/16"	193mm 7 5/8"
<b>TXX-BF15</b>	Ø388mm 15 1/4"	Ø351mm 13 7/8"	Ø370mm 14 9/16"	Ø190mm 7 1/2"	219mm 8 5/8"

## Aplicaciones de la Caja Sellada

Ventaja primaria: Es pequeña, mantiene una baja frecuencia magnífica, control y extensión simple para la construcción.

Este tipo de caja es de diseño clásico y el mas fácil de construir. Las recomendaciones para estas cajas han sido calculadas con suficiente ventilación en el interior e incluye el desplazamiento del woofer. Todos los diseños de cajas selladas deben ser rellenados con un 50% de relleno poly-fil. El uso de poly-fil podría decrecer un mínimo la eficiencia, pero profundiza y extiende las salidas de baja frecuencia.

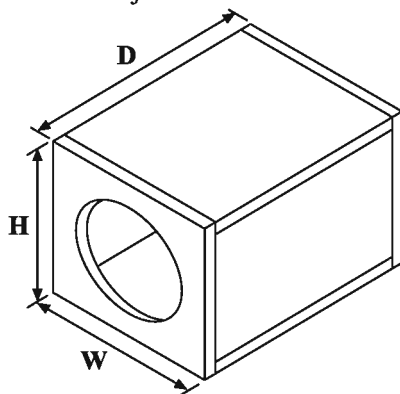

Subwoofer	Caja Sellada Recomendada	
	Volumen (net int.)	Dimensiones Externas (W=Ancho x H=Alto x D=Profundidad)
<b>TXX-BF10</b>	1.0 FT <sup>3</sup>	12" x 12" x 13"
<b>TXX-BF12</b>	1.75 FT <sup>3</sup>	14" x 14" x 16"
<b>TXX-BF15</b>	2.25 FT <sup>3</sup>	16" x 16" x 18"

### Notas acerca de la construcción de las cajas:

Use tabla de fibra de mediana densidad de 3/4" o mayor y selle las uniones con silicon. Todas las medidas en pies cúbicos en este manual incluyen el desplazamiento del woofer y el puerto. Todos los puertos han sido calculados usando puertos rectangulares, podría ser irreal el utilizar puertos redondos para estos diseños. No instale aberturas para puertos en superficies sólidas, tal como un puntal interno, el panel posterior ó el asiento de su vehículo. La abertura para el puerto debe permanecer sin obstrucción.

## Aplicaciones de Cajas con Orificios

Ventaja primaria: Es eficiente, tiene baja distorción en el puerto de sintonía.

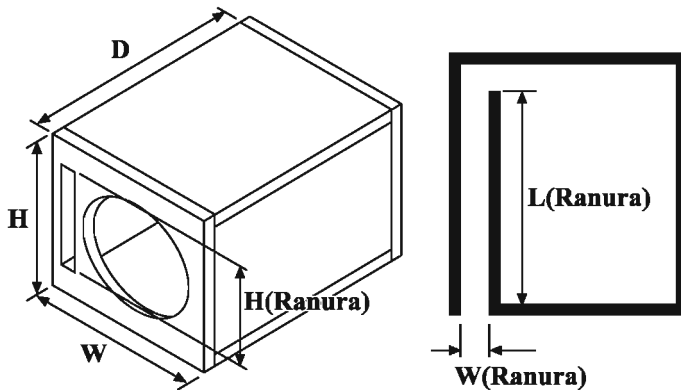

Estas cajas son las escogida por los instaladores para el alto rendimiento de los niveles SPL y requiere un conocimiento mas profundo para lograr una máxima eficiencia. Estas recomendaciones han sido calculadas con espacio interno ventilado e incluye el desplazamiento del woofer.

Subwoofer	Caja con Puerto Recomendada		
	Volumen (net int.)	Caja Dimensiones Externas (W=Ancho x H=Alto x D=Profundidad)	Dimensiones Internas de la Ranura del Puerto (Ranura: W=Ancho x H=Alto x L=Largo)
TXX-BF10	1.25 FT <sup>3</sup>	14" x 14" x 17.5"	1.25" x 9.5" x 16.5"
TXX-BF12	2.00 FT <sup>3</sup>	16" x 16" x 16"	1.25" x 11.5" x 16"
TXX-BF15	2.50 FT <sup>3</sup>	18" x 18" x 16"	1.25" x 14.5" x 15"

### Opciones de Cableado

La serie de subwoofers TXX-BF estan disponibles con bobinas duales de 4 Ohms. Las bobinas deben ser conectadas a una fuente de amplificación. Un woofer dual de 4 Ohms puede ser configurado en paralelo para proveer una carga de 1 Ohm. Un woofer dual de 4 Ohms puede ser tambien configurado en serie para proveer una carga de 8 Ohms. El terminal con la marca roja es el positivo, mientras que el terminal marcado en negro es el negative.

Series Wiring for  
Dual Voice Coil 2Ω Sub

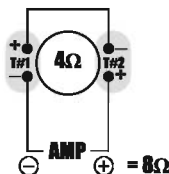

Parallel Wiring for  
One Dual Voice Coil 4Ω Subs

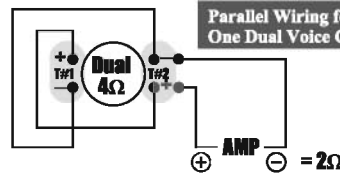

# Other useful wiring options

T#1 = Terminal #1

T#2 = Terminal #2

## Parallel Wiring for Two Single Voice Coil 4Ω Subs

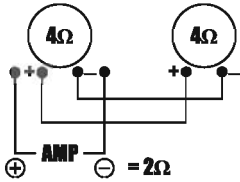

## Series/Parallel Wiring for Two Dual Voice Coil 2Ω Subs

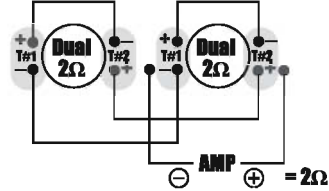

## Parallel Wiring for Four Single Voice Coil 4Ω Subs

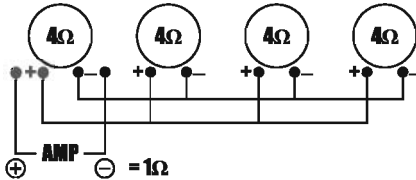

## Series/Parallel Wiring for Four Single Voice Coil 4Ω Subs

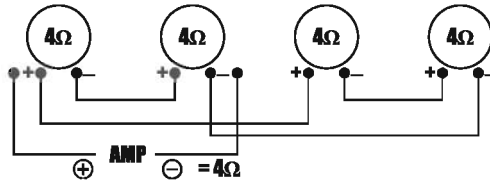

## Series/Parallel Wiring for Four Dual Voice Coil 4Ω Subs

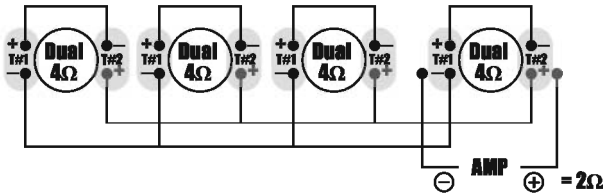

## Parallel Wiring for Dual Voice Coil 2Ω Sub

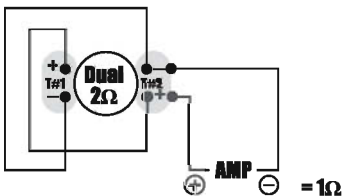

## Series Wiring for Dual Voice Coil 2Ω Sub

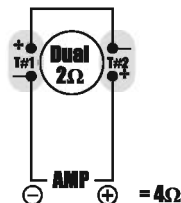

# Other useful wiring options

T#1 = Terminal #1

T#2 = Terminal #2

Series/Parallel Wiring for Three Dual Voice Coil 2Ω Subs

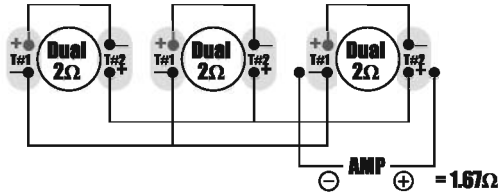

Parallel Wiring for One Dual Voice Coil 4Ω Subs

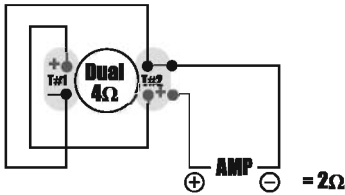

Parallel Wiring for Two Dual Voice Coil 4Ω Subs

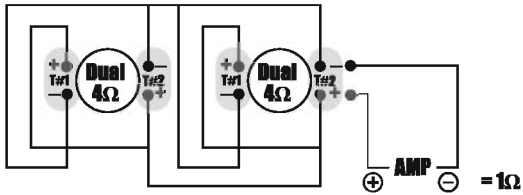

Series/Parallel Wiring for Four Dual Voice Coil 2Ω Subs

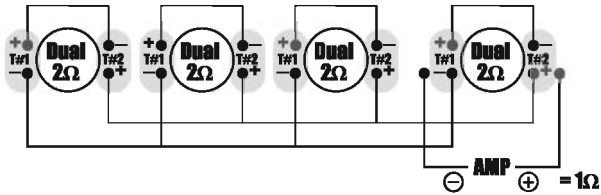

Series/Parallel Wiring for Three Dual Voice Coil 4Ω Subs

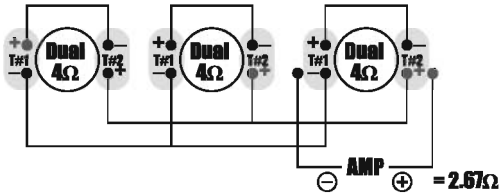

Series/Parallel Wiring for Two Dual Voice Coil 4Ω Subs

